

BELOW THE HOOK LIFTING NEEDS ANALYSIS: LIGHT WEIGHT PALLET LIFTER – MODEL 40

Used for handling pallets with an overhead crane

Two bar positioner eliminates the need for a counter weight, and keeps the lifter light weight

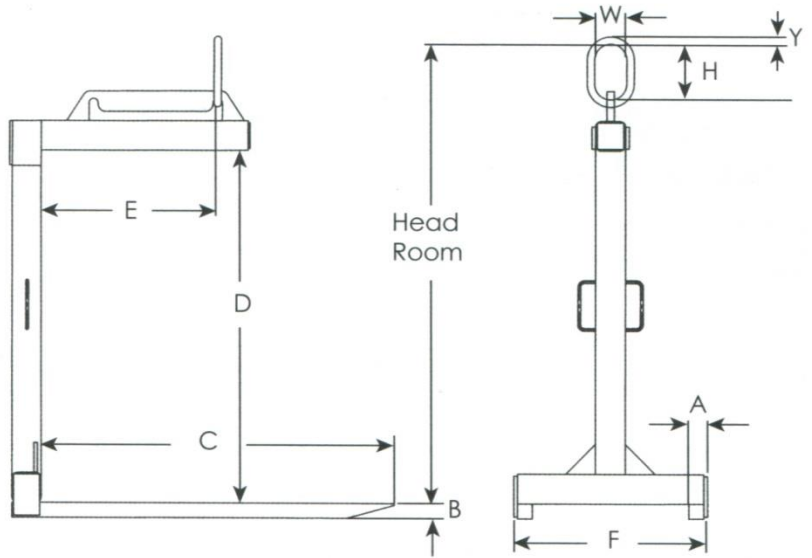

**Light Weight Pallet Lifter
Nominal Dimensions**

Catalog #	Capacity	Forks (inch)				Bail (inch)				Head Room	
		C	A	B	F	E	Y	W	H		D
40-1-48	1 Ton	36	2	2	25	24	1/2	2-1/2	5	48	58
40-2-48	2 Ton	36	4	2	25	24	3/4	2-3/4	5-1/2	48	62
40-3-48	3 Ton	36	4-1/2	2-1/2	27	24	1	3-1/2	5	48	65

Design Your Own Light Weight Pallet Lifter: (Engineering must approve any modification)

Capacity: _____ C: _____ A: _____ B: _____

F: _____ E: _____ Y: _____ W: _____

H: _____ D: _____ Head Room: _____

Notes / Crane Hook Requirements: _____



Wisconsin Lifting Specialists

“The SMART CHOICE in Lifting and Rigging Products”

Toll Free: 800-242-4449

www.wisconsinlifting.com

Client Contact Information:

Company: _____

Contact: _____

Phone / Fax: _____

Email: _____